

Overview

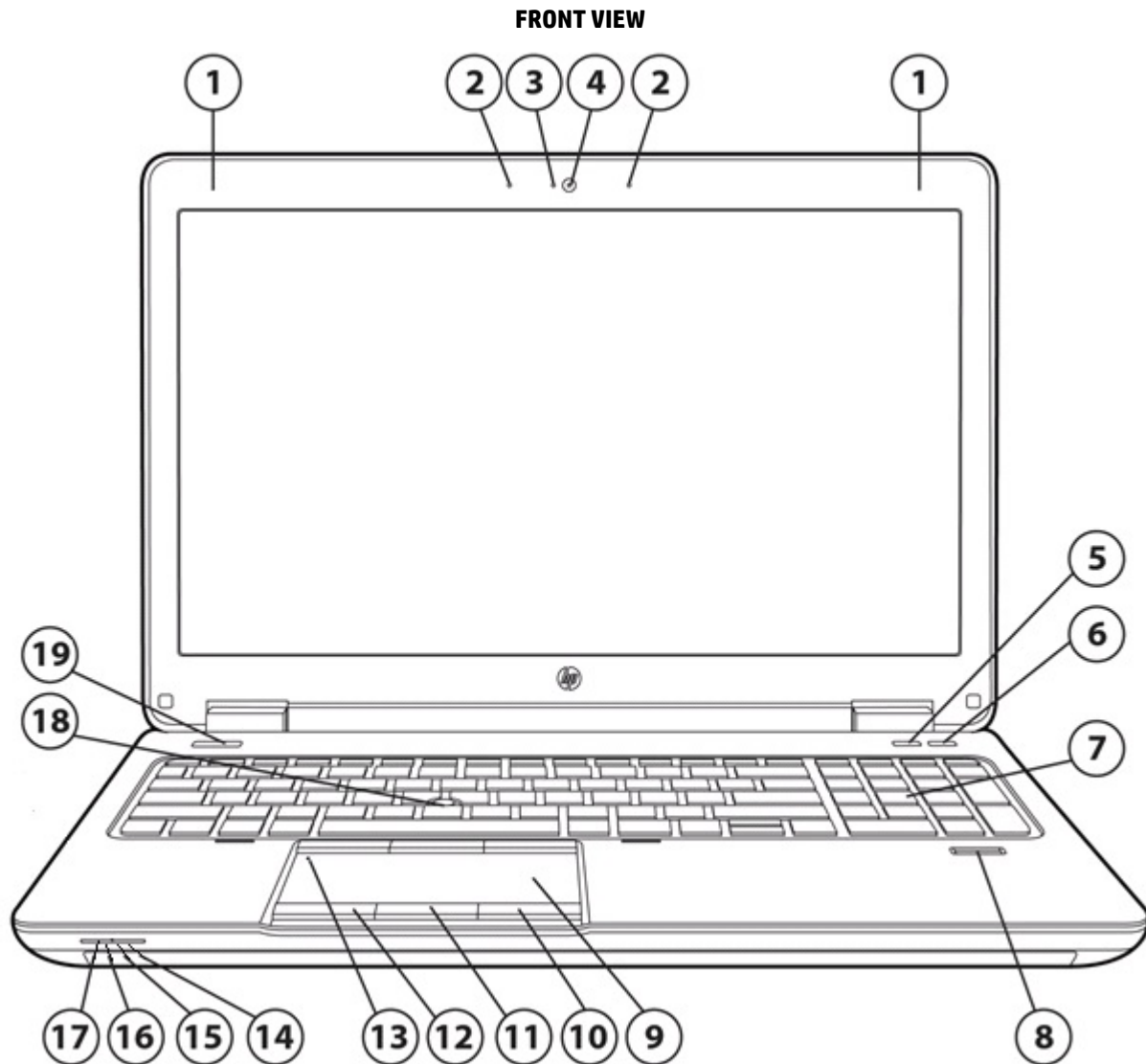

- | | |
|--|-------------------------------------|
| 1. WLAN antennas (2) | 11. Center Touchpad button |
| 2. Internal microphones (2) | 12. Left Touchpad button |
| 3. Webcam light (with webcam) | 13. Touchpad on/off button with LED |
| 4. Webcam | 14. Hard drive light |
| 5. Wireless button | 15. AC adapter/Battery light |
| 6. Volume mute button | 16. Power light |
| 7. Numeric keypad | 17. Wireless light |
| 8. Fingerprint reader (select models only) | 18. Pointstick |
| 9. Touchpad with scroll zone | 19. Power button |
| 10. Right Touchpad button | |

Overview

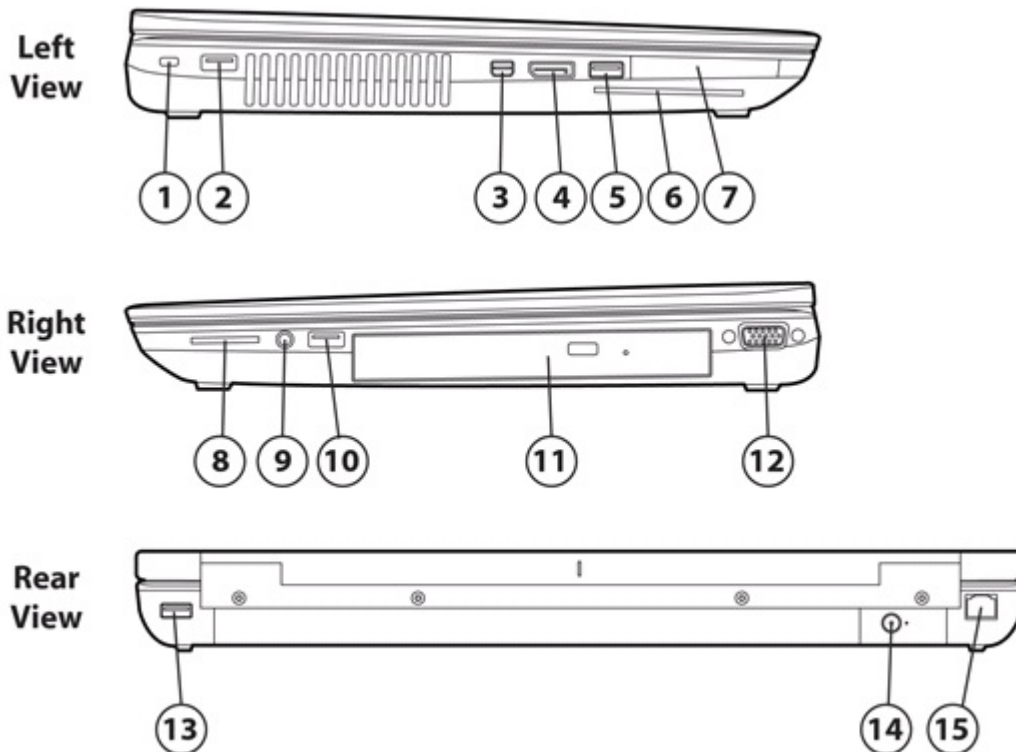

- | | |
|--------------------------|--|
| 1. Security cable slot | 9. Audio-out (headphone) jack/Audio in (microphone) jack |
| 2. USB 2.0 port | 10. USB 3.0 port |
| 3. Thunderbolt port* | 11. Optical drive (select models only) |
| 4. DisplayPort | 12. External monitor port |
| 5. USB 3.0 charging port | 13. USB 3.0 port |
| 6. Smart card reader | 14. Power connector |
| 7. ExpressCard port | 15. RJ-45 (network) jack/lights (2) |
| 8. Memory card reader | |

* Thunderbolt is new technology. Install all the latest drivers for your Thunderbolt device before connecting the device to the Thunderbolt port. Thunderbolt cable and Thunderbolt device (sold separately) must be compatible with Windows. To determine whether your device is Thunderbolt Certified for Windows, see <https://thunderbolttechnology.net/products>.

At A Glance

- Windows 8.1 versions, Windows 7 versions, Ubuntu Linux, or FreeDOS
- Thin and light form factor and industrial design. Durable HP Duracase with magnesium-reinforced chassis, HP DuraFinish with brushed aluminum on top cover and smooth aluminum around top, right, and left sides chassis with hematite /graphite color, HP DisplaySafe frame, latch-less design with precision aluminum-alloy hinges, backlight keyboard in full aluminum deck, chemically strengthened glass touchpad, and updated system functions indicators
- Designed to meet the military standard Mil-Std-810G for drop, vibration, shock, high temperature, low temperature, temperature shock, dust, altitude, and humidity*
- Workstation-caliber NVIDIA® Quadro® discrete graphics—NVIDIA Quadro K610M (1GB GDDR5), NVIDIA Quadro K1100M (2GB GDDR5), AMD FirePro™ M5100 (2GB GDDR5), NVIDIA Quadro K2100M (2GB GDDR5)†NVIDIA Optimus or AMD Enduro™ technology enabled for improved battery life.
- ISV certified to provide fast and reliable performance with workstation applications, including manipulation of 3D textures
- Choice of 4th generation Intel® Core™ i7 and i5 processors
- Intel Core i7 with vPro and Core i5 with vPro technology (optional) ****

Overview

- Intel Smart Response Technology support for higher system performance with a hard drive
- HP Performance Advisor for optimal configuration, compatibility and performance
- Up to four SODIMMs on configurations with quad-core processor, for system memory up to 32 GB
- Supports multi-display, including up to four without a docking station (both with and without hybrid graphics enabled), up to four with HP Advanced Docking Station (sold separately) without hybrid graphics enabled and up to five with HP Advanced Docking Station (sold separately) and hybrid graphics enabled
- New Thunderbolt 2 port** for high speed data/video/audio transfer support
- Thunderbolt 2 port can be connected to monitors supporting DisplayPort 1.2 to achieve HBR2 and MST functionality.
- DTS Studio Sound HD audio optimized for high fidelity audio with immersive surround sound with deep, rich bass and crystal clear dialog without distortion at high volume
- Choice of battery solutions—8-cell (83 WHr) or 8-cell (75 WHr) HP Long Life Battery, combined with optional external batteries for extended life.
- 2 discrete buttons with LED indicator for convenient one touch access - Wireless On/Off, Volume Mute
- Widescreen 15.6-inch diagonal anti-glare LED-backlit display—HD (1920x1080) eDP with standard viewing angle, FHD (1920x1080) eDP with PSR (Panel Self Refresh) with ultrawide viewing angle, QHD+ (3200x1800) eDP with ultrawide viewing angle
- Upgrade Bay for optional second hard drive or weight saver
 - Flexible wireless connectivity options—
 - Intel Dual Band Wireless-N 7260 802.11 a/b/g/n (2x2) WiFi 7Intel Dual Band Wireless-AC 7260 802.11 a/b/g/n/ac (2x2) WiFi and Bluetooth 4.0 combo7Intel Dual Band Wireless-AN 7260 802.11 a/b/g/n (2x2) WiFi and Bluetooth 4.0 combo
 - Optional integrated wireless 3G or 4G (LTE) mobile broadband module support
- Choice of tool free capable, user-removable hard drive up to 1 TB with HP 3D DriveGuard protection, or SATA 6 Gb/s 128/180/240/256/512*** GB Solid State Drive, 256 GB Z Turbo Drive (PCIe SSD)
- Security features including HP Client Security Manager, managed via single console
- Low halogen***
- HP BIOS technology, including HP Sure Start to identify and recover from known and unknown BIOS attacks.

* MIL-STD-810G testing is pending and is not intended to demonstrate fitness for U.S. Department of Defense contracts or for military use. Test results are not a guarantee of future performance under these test conditions.

** Thunderbolt is new technology. Install all the latest drivers for your Thunderbolt device before connecting the device to the Thunderbolt port. Thunderbolt cable and Thunderbolt device (sold separately) must be compatible with Windows. To determine whether your device is Thunderbolt Certified for Windows, see <https://thunderbolttechnology.net/products>.

*** External power supplies, power cords, cables and peripherals are not low halogen. Service parts obtained after purchase may not be low halogen.

**** Multi-Core is designed to improve performance of certain software products. Not all customers or software applications will necessarily benefit from use of this technology. 64-bit computing system required. Performance will vary depending on your hardware and software configurations. Intel's numbering is not a measurement of higher performance. Some vPro functionality, such as Intel® Active management technology and Intel Virtualization technology, requires additional 3rd party software in order to run. Availability of future virtual appliances and applications for Intel vPro technology is dependent on 3rd party software providers. Microsoft Windows required.

Features

OPERATING SYSTEM

Preinstalled

Windows 8.1 Pro 64*
Windows 7 Professional 64 (available through downgrade rights from Windows 8.1 Pro)**
Windows 8.1 64*
Windows 7 Professional 64**
Ubuntu Linux***
FreeDOS

Supported

Windows 8.1 Enterprise 64*
Windows 7 Enterprise 64**

Certified

* Not all features are available in all editions or versions of Windows. Systems may require upgraded and/or separately purchased hardware, drivers and/or software to take full advantage of Windows functionality. See <http://www.microsoft.com> for details.

** This system is preinstalled with Windows® 7 Pro software and also comes with a license and media for Windows 8 Pro software. You may only use one version of the Windows software at a time. Switching between versions will require you to uninstall one version and install the other version. You must back up all data (files, photos, etc.) before uninstalling and installing operating systems to avoid loss of your data.

*** Not available with WWAN

PROCESSOR*

4th Generation Intel® Core™ i7-4910MQ (2.9 GHz, 1600MHz, 8 MB L3 cache, 4 cores, 47W)*

Up to 3.90 GHz with Intel Turbo Boost Technology

4th Generation Intel® Core™ i7-4810MQ (2.8 GHz, 1600MHz, 6 MB L3 cache, 4 cores, 47W)*

Up to 3.80 GHz with Intel Turbo Boost Technology

4th Generation Intel® Core™ i7-4710MQ (2.5 GHz, 1600MHz, 6 MB L3 cache, 4 cores, 47W) (no vPro support)*

Up to 3.50 GHz with Intel Turbo Boost Technology

4th Generation Intel® Core™ i7-4610M (3.00 GHz, 1600 MHz, 4 MB L3 Cache, 2 cores, 37W)

Up to 3.70 GHz with Intel Turbo Boost Technology

4th Generation Intel® Core™ i5-4340M (2.90 GHz, 1600 MHz, 3 MB L3 Cache, 2 cores, 37W)

Up to 3.60 GHz with Intel Turbo Boost Technology

Intel Dual-Core i5-4210M (3.20 GHz, 1600 MHz, 3 MB L3 Cache, 4 threads, 37W)

Up to 3.20 GHz with Intel Turbo Boost Technology

* Multi-Core is designed to improve performance of certain software products. Not all customers or software applications will necessarily benefit from use of this technology. 64-bit computing system required. Performance will vary depending on your hardware and software configurations. Intel's numbering is not a measurement of higher performance.

NOTE-NVIDIA Optimus is enabled by default. If you choose to disable this functionality, Intel® integrated graphics will not be used.

CHIPSET

Mobile Intel® QM87

Features

INTEL® CORE™ I5 WITH VPRO/CORE™ I7 WITH VPRO TECHNOLOGY CAPABLE

Intel Core i5 with vPro and Core i7 with vPro technology is a selectable feature that is available on units configured with select processors, a qualified Intel Centrino® WLAN module and a preinstalled Windows operating system. It provides advances in remote manageability, security, energy efficient performance, and wireless connectivity. Intel Active Management Technology 9.0 (iAMT) offers built-in manageability and proactive security for networked mobile workstations, even when they are powered off* or when the operating system is inoperable. It can help identify threats before they reach the network, isolate infected systems, and update mobile workstations regardless of their power state.

*Requires a Windows operating system, network hardware and software, connection with a power source, and a direct (non-VPN) corporate network connection which is either cable or wireless LAN.

NOTE—Some functionality of Intel Core i5 with vPro/Core i7 with vPro technology, such as Intel Active Management technology and Intel Virtualization technology, requires additional third-party software in order to run. Availability of future virtual appliances and applications for Intel Core i5 with vPro/Core i7 with vPro technology is dependent on third-party software providers. Compatibility with future virtual appliances is yet to be determined.

GRAPHICS

NVIDIA Quadro K610M with 1 GB dedicated GDDR5 video memory
Microsoft DirectX 11.1 (Shader Model 5.0) and OpenGL 4.2 capable
NVIDIA Quadro K1100M with 2 GB dedicated GDDR5 video memory
Microsoft DirectX 11.1 (Shader Model 5.0) and OpenGL 4.2 capable
AMD FirePro™ M5100 with 2 GB dedicated GDDR5 video memory
Microsoft DirectX 11.1 (Shader Model 5.0) and OpenGL 4.2 capable
NVIDIA Quadro K2100M with 2 GB dedicated GDDR5 video memory
Microsoft DirectX 11.1 (Shader Model 5.0) and OpenGL 4.2 capable

NVIDIA Optimus Technology and AMD Enduro™ Technology supported

NOTE—NVIDIA Quadro mobile professional graphics support up to five independent displays when using an HP Advanced Docking station (sold separately). AMD FirePro™ professional graphics support up to five independent displays when using an HP Advanced Docking station (sold separately).

Multi-Display Support

Without Docking Station⁻

HP ZBook 15 without the use of a Docking Station supports up to a maximum of four independent displays. These four displays are the internal panel plus three external displays connected to the VGA, the DisplayPort (DP), and the Thunderbolt™ Port connectors.

With Docking Station^{*-}

The Advanced Docking Station has VGA and four digital display output connectors (two DVI and two DP). Of those four digital display connectors, only two may be used at a time (two DVI, two DP or one DP and one DVI). When used together with the HP ZBook 15, a maximum of five independent displays are supported. These five displays are the internal panel plus four external displays connected to three display outputs connectors from the standard or Advanced Docking Station*, and the Thunderbolt™ connector from the ZBook.

DP 1.2 Daisy-chain⁻ feature⁻

On HP ZBook 15, the maximum number of independent displays is increased to six with the use of DP1.2 Daisy-chain⁻ feature. This requires Hybrid Graphics to be enabled, one monitor connected to the dock VGA, and at least one daisy chain connection on (A) System DP, (B) Docking Station DP 1, (C) Docking Station DP 2.

* Advanced docking station sold separately.

Features

DISPLAY

Internal

15.6" diagonal LED-backlit FHD SVA eDP anti-glare (1920 x 1080)

15.6" diagonal LED-backlit FHD UWVA IPS eDP anti-glare + Panel Self Refresh (PSR) (1920 x 1080)

15.6" diagonal RGB LED-backlit FHD UWVA IPS eDP anti-glare (1920 x 1080)

External

Up to 32-bit per pixel color depth

Thunderbolt™ 2*

Supported as part of the daisy chain connected with Intel approved thunderbolt cables. For additional information, please visit <https://thunderbolttechnology.net/>.

Thunderbolt™ Features

- Legacy DP 1.1a, DVI-A/D, HDMI and VGA displays attached to the end of the thunderbolt daisy chain via Intel certified dongles
- DP 1.2 redrive DP DisplayPort monitors capable of supporting DP 1.2 may be directly attached to the Thunderbolt port to achieve HBR2 and MST functionality.
- DP display with miniDP connector may be attached directly to TB (Thunderbolt) port.
- DP display with standard DP connector and other legacy displays (HDMI, DVI, VGA) may be attached to TB with the use of a dongle.
- DP1.2 MST feature (daisy-chain feature) is supported through TB port.

* Thunderbolt™ 2 is new technology. Install all the latest drivers for your Thunderbolt device before connecting the device to the Thunderbolt port. Thunderbolt cable and Thunderbolt device (sold separately) must be compatible with Windows. To determine whether your device is Thunderbolt Certified for Windows, see <https://thunderbolttechnology.net/products>.

DisplayPort w/MST (Multi-stream Transport)

Supports resolutions up to QFHD 3840 x 2160, 24/30-bit color depth at 60 Hz, and WUXGA (1920 x 1200) monitors, 24/30-bit color depth at 120 Hz.

DisplayPort Feature

- Multi-stream Transport (MST) Multi-stream Transport is a DP 1.2 feature that allows daisy chaining of DP 1.2 monitors (requires built in support of DP 1.2 MST in monitor), or the use of DP 1.2 hubs with MST to achieve 4 active displays without a docking station.

VGA

Port supports resolutions up to 2048 x 1536 at 75 Hz, and lower resolutions at up to 100 Hz

DVI-D (single link)

Video signal available through DVI port in optional HP Docking Station (sold separately), as well as through DisplayPort to DVI-D DisplayPort to DVI-D (dual link) and DisplayPort to HDMI adapters.

Supports resolutions up to 1600 x 1200 at both full and reduced blanking, and 1920 x 1200 at reduced blanking

NOTE Resolutions are dependent upon monitor capability, and resolution and color depth settings.

Features

STORAGE AND DRIVES

Z Turbo Drive Storage Bay

256 GB Z Turbo Drive (PCIe Solid State Drive)

Primary Storage Bay

Hard Drives*

500/750 GB, 1 TB 7200 rpm SMART SATA II

500 GB 7200 rpm SMART SATA II Self Encrypting Drive

500 GB 5400 rpm SMART SATA II Self Encrypting Drive FIPS 140-2 compliant

HP 3D DriveGuard (Windows only)

The hard drive is mounted directly to the notebook frame, reducing the transmission of shock to the hard drive. Uses three-axis digital motion detection with intelligent sensitivity to help protect the hard drive during normal use from shock and vibration. The digital accelerometer temporarily halts all data transfer and parks the hard drive when abrupt motion is detected.

Solid State Drive*

128/180/240/256/512 GB SATA 6 Gb/sec

NOTE: For storage drives, GB = 1 billion bytes. TB = 1 trillion bytes. Actual formatted capacity is less. Up to 16 GB (for Windows 7) of system and up to 30 GB (for Windows 8) disk is reserved for system recovery software.

DRIVE CONTROLLERS

Primary drive and upgrade bay²

Z Turbo Drive²

RAID²

SATA-3 or SATA-2 for HDD and SATA-3 for SSD

PCIe SSD

0 and 1 supported

OPTICAL DRIVES

Fixed 9.5 mm SATA optical drive

Blu-ray R/RE DVD+/-RW SuperMulti DL Drive*,**

Blu-ray ROM DVD+/-RW SuperMulti DL Drive *,**

DVD+/-RW SuperMulti DL Drive**

*With Blu-Ray, certain disc, digital connection, compatibility and/or performance issues may arise, and do not constitute defects in the product. Flawless playback on all systems is not guaranteed. In order for some Blu-ray titles to play, they may require a DVI or HDMI digital connection and your display may require HDCP support. HD-DVD movies cannot be played.

**Double Layer discs can store more data than single layer discs. However, double-layer discs burned with this drive may not be compatible with many existing single-layer DVD drives and players. The DVD-RAM cannot read or write to 2.6GB Single Sided/5.2 GB Double Sided - Version 1.0 media.

Second hard drive

750 GB 7200 rpm SMART SATA II Hard Drive

512 GB SATA 6 Gb/sec Solid State Drive

256 GB SATA 6 Gb/sec Self Encrypting Drive

RAID 0 and 1 supported

Weight saver

Features

MEMORY

Standard

DDR3L 1.35V SDRAM (1600 MHz)

Two SODIMM slots (Dual-core processor) or four SODIMM slots (Quad-core processor) supporting dual-channel memory
2 GB, 4 GB, and 8 GB SODIMMs

Maximum

Upgradeable to 16384 MB with optional 8192 MB SODIMMs in both slots (Dual-core processor)

Upgradeable to 32768 MB with optional 8192 MB SODIMMs in all 4 slots (Quad-core processor)

Dual-channel

Maximized dual-channel performance requires SODIMMs of the same size and speed in both memory slots.

NOTE-Due to the non-industry standard nature of some third-party memory modules, we recommend HP branded memory to ensure compatibility. If you mix memory speeds, the system will perform at the lower memory speed.

Maximum memory capacities assume Windows 64-bit operating systems or Linux.

NETWORKING/COMMUNICATIONS

Wireless

Support for a broad range of secure, integrated wireless LAN and wireless WAN options featuring support for the latest industry standards. Optional broadband Wireless (WWAN) requires a Windows operating system and is available in select countries as a standard, factory configurable feature only. Integrated Bluetooth® is also available (factory configurable only) and can be combined with any of the supported wireless LAN and wireless WAN options.

Mobile Broadband options

HP hs3110 HSPA+ Mobile Module

HP lt4112 LTE/HSPA+ Qualcomm® Gobi™ 4G Module

HP lt4211 LTE/EV-DO/HSPA+ Gobi 4G Module

All 802.11 integrated wireless LAN options

Intel Dual Band Wireless-NB 7260 802.11 a/b/g/n (2x2) WiFi

Intel Dual Band Wireless-AC 7260 802.11 a/b/g/n/ac (2x2) WiFi and Bluetooth 4.0 combo

Intel Dual Band Wireless-AN 7260 802.11 a/b/g/n (2x2) WiFi and Bluetooth 4.0 combo

Communications

Integrated Intel® I217-LM Gigabit** Network Connection (vPro configurations)

* Broadband wireless is an optional feature and requires separately purchased service contract. Check with your local vendor for coverage area and availability in your area. Connection and speeds will vary due to location, environment, network conditions, and other factors. 4G LTE not available on all products, in all regions.

** The term 10/100/1000 or Gigabit Ethernet indicates compatibility with IEEE standard 802.3ab for Gigabit Ethernet, and does not connote actual operating speed of 1 Gb/s. For high-speed transmission, connection to a Gigabit Ethernet server and network infrastructure is required.

*** Integrated Intel® Wi-Di feature is available on select configurations only and requires separately purchased projector, tv or computer monitor with an integrated or external Wi-Di receiver. External Wi-Di receivers connect to the projector, tv or computer monitor via a standard HDMI cable, also sold separately.

****802.11 requires access point and internet service. Availability of public wireless access points limited.

Features

AUDIO/MULTIMEDIA

Audio

DTS Studio Sound HD audio (Windows OS only)

Integrated stereo speakers

Integrated microphone (dual-microphone array when equipped with optional webcam)

Button for volume mute²/function keys for volume up and down

Combo mic-in / stereo headphone-out jack

Webcam

Optional 720p HD webcam

- HD format (widescreen)
- Supports videoconferencing and still image capture
- High quality fixed focus lens
- Video capture at various resolutions up to 1280x720 resolution (720p) and up to 30fps
- M-JPEG compression supports higher frame rates for video capture and videoconferencing
- Improved low light sensitivity
- Improved dynamic range

KEYBOARDS/POINTING DEVICES/BUTTONS & FUNCTION KEYS

Keyboard

Optional backlit keyboard with Function key control to toggle backlit brightness setting - off/full/half brightness

The HP spill-resistant keyboard is designed using a thin layer of Mylar film under the keyboard and a drain system that funnels fluid through a hole in the bottom of the notebook. This minimizes the risk of damage to sensitive components underneath. The 101/102-key compatible keyboard features a full-pitch key layout with desktop keyboard features, such as editing keys, both left and right control and alt keys, function keys, and 19.05 x 19.05 mm key pitch (center-to-center spacing). U.S. and International key layouts are available. Other features include hot keys for instant access to power conservation and brightness.

Pointing Devices

Touchpad with On/Off button, two-way scroll, gestures, three pick buttons

Pointstick with three additional pointstick buttons

Image sensor touchpad for enhanced performance and improved precision on scroll and gesture

Buttons and Function Keys

Separate launch buttons provide easy access to the following features²-wireless on/off, volume mute. Function keys provide control of the following features²-standby mode, external display, volume down, volume up, HP Power Assistant (Windows 7 only), and display brightness.

SOFTWARE AND SECURITY

Preinstalled Software with Windows Operating System

Windows 8

Security

HP Device Access Manager with Just In Time Authentication

DigitalPersona Fingerprint Driver

HP Drive Encryption¹

HP File Sanitizer²

HP Client Security Manager

Windows 7

Security

HP Device Access Manager with Just In Time Authentication

HP Drive Encryption

HP File Sanitizer

HP Client Security Manager

HP SpareKey

Features

HP SpareKey
Microsoft Defender
Validity Fingerprint Driver

BIOS Features

Absolute Persistence Module³
HP Sure Start
HP Automatic Drive Lock⁴
HP BIOS Protection
HP Disk Sanitizer (Not for SSD)⁵
HP DriveLock⁶
HP SpareKey
Hybrid Boot
Master Boot Record Security
Measured Boot
Power On Authentication
Pre-Boot Security
Secure Boot
Secure Erase (SSD & HDD)⁷
BIOS Update via Network

MultiMedia

Cyberlink Power2Go
Cyberlink PowerDVD

HP Value Add

Getting Started with Windows 8
HP 3D DriveGuard⁸
HP ePrint Driver⁹
HP Hotkey Support
HP Manageability
HP PageLift App¹⁰
HP Support Assistant
Foxit PhantomPDF Express for HP
Skype

Microsoft Products

Buy Office

Additional Software Available from the Web

HP SoftPaq Download Manager
HP Software System Manager

Workstation ISV Certifications

See the latest list of certifications at <http://www.hp.com/united-states/campaigns/workstations/partnerships.html>

Microsoft Security Essentials
Validity Fingerprint Driver

BIOS Features

Absolute Persistence Module
HP Sure Start
HP Automatic Drive Lock
HP BIOS Protection
HP Disk Sanitizer (Not for SSD)
HP DriveLock
HP SpareKey
Hybrid Boot
Master Boot Record Security
Measured Boot
Power On Authentication
Pre-Boot Security
Secure Erase (SSD & HDD)
BIOS Update via Network

MultiMedia

Cyberlink Power2Go
Cyberlink PowerDVD
Cyberlink YouCam BE

HP Value Add

HP 3D DriveGuard
HP ePrint Driver
HP Hotkey Support
HP Manageability
HP PageLift
HP Recovery Manager
HP Support Assistant
HP Recovery Disc Creator (HPRDC)
Foxit PhantomPDF Express for HP
Skype

Microsoft Products

Buy Office

Features

HP Remote Graphics Software

The remote desktop solution for serious workstation users and their most demanding applications.

Download at www.hp.com/go/RGS

HP Performance Advisor

HP Performance Advisor enables optimal configuration of HP Mobile Workstations delivering stability and best performance. HP Performance Advisor will guide your system setup allowing a custom configuration that best matches the workstation to user requirements.

Download at www.hp.com/go/performanceadvisor

HP Recovery Manager

Models shipped with Windows 7 include HP Recovery Manager. HP Recovery Manager enables fast recovery of the factory preinstalled image if the system becomes corrupted or if important system files are accidentally deleted. Up to 36 GB (for Windows 7) of system and up to 36 GB (for Windows 8) disk is reserved for system recovery software.

Security

See Software section above.

Other Standard Security Features

Integrated Smart Card Reader

HP Spare Key (requires initial user setup)

One-Step Logon

Common Criteria EAL4+ Augmented Certified Discrete TPM 1.2 Embedded Security Chip

Security lock slot

Support for Intel AT¹¹

Optional Security Features

HP Fingerprint Sensor (optional)

Computrace* with GPS Tracking - Subscription based security solution providing the ability to track, initiate physical recovery, conduct asset management, and perform remote data delete by utilizing GPS technology. GPS functionality requires HP Mobile Broadband Module.

* The Computrace agent is shipped turned off, and must be activated by customers when they purchase a subscription.

Subscriptions can be purchased for terms ranging multiple years. Service is limited, check with Absolute for availability outside the U.S.

¹ HP Drive Encryption requires Windows. Data is protected prior to login. Turning the PC off or into hibernate logs out of Drive Encryption and prevents data access.

² File Sanitizer requires Windows. For the use cases outlined in the DOD 5220.22-M Supplement. Does not support Solid State Drives (SSDs). Initial setup required. Web history deleted only in Internet Explorer and Firefox browsers and must be user enabled. With Windows 8.1, user must turn off Enhanced Protection Mode in IE11 for shred on browser close feature.

³ BIOS Absolute Persistence module is shipped turned off, and will be activated when customers purchase and activate a subscription. Service may be limited. Check with Absolute for availability outside the U.S. The optional subscription service of Absolute Recovery Guarantee is a limited warranty. Certain conditions apply. For full details visit <http://www.absolute.com/company/legal/agreements/computrace-agreement>. If Data Delete is utilized, the Recovery Guarantee payment is null and void. In order to use the Data Delete service, customers must first sign a Pre-Authorization Agreement and either create a PIN or purchase one or more RSA SecurID tokens from Absolute Software.

⁴ HP Automatic DriveLock will work on another HP Business PC when the BIOS passwords are the same. Requires user set up.

⁵ For the use cases outlined in the DOD 5220.22-M Supplement. Does not support Solid State Drives (SSDs).

⁶ HP DriveLock does not support Self Encrypting HDs (SEDs) if the encryption PIN is enabled.

Features

⁷ HP Secure Erase is for the methods outlined in the National Institute of Standards and Technology Special Publication 800-88.

⁸ HP 3D DriveGuard requires Windows.

⁹ HP ePrint requires an Internet connection to HP web-enabled printer and HP ePrint account registration (for a list of eligible printers, supported documents and image types and other HP ePrint details, see www.hp.com/go/businessmobileprinting)

¹⁰ HP PageLift requires Windows 7 or higher.

¹¹ Intel AT security requires a separately purchased Absolute Computrace service subscription and must be activated and configured. Check with Absolute for availability in your country. Intel and HP assume no liability for lost or stolen data and/or systems or any other damages resulting therefrom. See <http://www.intel.com/technology/anti-theft/>

HP CENTRAL MANAGEMENT

HP offers a variety of scalable hardware, software, and BIOS-based security features to help you defend your organization against viruses and other threats. These integrated security features safeguard what matters to you the most - your data, device and identity. Now, be confident your fleet of devices is protected in multiple layers of HP Client Security protection.

HP BIOS Protection keeps you up and running with enhanced protection against virus attacks and other threats. And if the BIOS is accidentally compromised, the auto recovery feature automatically restores it to its fully functional state.

HP Sure Start detects and negates a BIOS attack with automatic recovery of the BIOS even when the installation is accidentally compromised (i.e. power outage). When HP Sure Start heals the BIOS an event log is generated that an IT administrator can retrieve so the business is aware of a BIOS attack. Golden copy of BIOS is stored in protected nonvolatile memory providing redundant, hardware-based protection against a new generation of attacks. This helps to future-proof your technology and business.

An optional fingerprint reader and integrated Smart Card Reader help keep your identity secure. The security cable slot helps keep your notebook physically secure.

HP Drive Encryption+ with TPM enhanced security protects your data on your hard drive from unauthorized access. Authentication is required before Windows will even start.

Or you can even permanently destroy data on your hard drive in preparation for your system disposal or redeployment with Secure Erase.

This hardware-based solution encrypts and decrypts data as it is written or read from the hard drive and is supported by HP Drive Encryption+. You get faster encryption performance than that of software-based encryption solutions.

+ Requires Windows. Data is protected prior to Drive Encryption login. Turning the PC off or into hibernate logs out of Drive Encryption and prevents data access.

HP provides a separate management solution, targeted at the enterprise and the SMB-

Digital Persona Pro Workgroup-Designed for the small business customer. Provides features similar to the Active Directory version, but for workgroups. Workgroup activation is built into HP ProtectTools, and activation of up to 5 seats is completely free.

For more information on Central Management for HP ProtectTools, refer to <http://www.hp.com/products/security>

Features

POWER

Power Supply

External HP 150W Slim Smart AC adapter
(167.0 x 82.0 x 25.4mm)

External HP 200W Slim Smart AC adapter
(172 x 96 x 25.4mm)

Power cord included is 6-foot (1.8 meter).

Total length including external AC adapter is 12 feet (3.66 meter).

HP Fast Charge*

Primary Battery

HP 8-cell Lithium-Ion Battery (83 WHr)

HP Long Life 8-cell Lithium-Ion Battery (75 WHr) **

Secondary Battery

HP BB09 Ultra Extended Life Notebook Battery (9-cell/100 WHr)

HP ST09 Extended Life Notebook Battery (9-cell/73 WHr)

Battery Life

Battery life up to xx hours and xx minutes***

System Standby Time

In sleep mode 1 week

* HP Fast Charge recharges your battery up to 90% within 90 minutes when the system is off. HP Fast Charge does not apply to the HP ST09 Extended Life Notebook Battery or HP BB09 Ultra Extended Life Notebook Battery.

** Available with 3-year warranty only

***Battery life will vary depending on the product model, configuration, loaded applications, features, use, wireless functionality and power management settings. The maximum capacity of the battery will naturally decrease with time and usage. See MobileMark07 battery benchmark <http://www.bapco.com/products/mobilemark2007> for additional details.

Power Conservation

NVIDIA Optimus technology

Hibernation

Standby

ACPI compliance

ENVIRONMENTAL

US ENERGY STAR®

IT ECO declaration

EPEAT®

Features

WEIGHTS & DIMENSIONS

Weight

Starting at 6.13 lb (2.78 kg) with Z Turbo Drive and weight saver (no optical drive)

Starting at 6.45 lb (2.93 kg) with hard drive and DVD-R/W drive

Dimensions (w x d x h)

1.2 in (at front)/1.4 in (at rear) x 15.0 in x 10.1 in

30.5 mm (at front)/35.5 mm (at rear) x 381.5 mm x 257.0 mm

NOTE—Height varies depending upon where on the notebook the measurement is made. Weight varies by configuration and components. Weight includes 8-cell battery, hard drive, 1 GB memory, and no optical drive. Weight varies by configuration and components.

PORTS/SLOTS

Ports

VGA - One

DisplayPort v1.2- One

Thunderbolt™ 2* - One

Stereo microphone in / headphone-out combo jack - One

Power Connector - One

Secondary Battery Connector - One

Docking Connector - One

RJ-45 (Ethernet) - One

USB 3.0 - Two

USB 3.0 Charging Port - One

USB 2.0 - One

Security lock slot - One

Digital Media Slots

ExpressCard/54 slot – One (Supports ExpressCard/54)

SD UHS-II Flash Media slot – One (Supports next generation SD (Secure Digital), backward compatible to SDHC, SDXC,

Integrated Smart Card Reader (Compatible with ISO 7816 compliant Smart Cards PC/SC interface support)

* Thunderbolt™ 2 is new technology. Install all the latest drivers for your Thunderbolt device before connecting the device to the Thunderbolt port. Thunderbolt cable and Thunderbolt device (sold separately) must be compatible with Windows. To determine whether your device is Thunderbolt Certified for Windows, see <https://thunderbolttechnology.net/products>

SERVICE AND SUPPORT

HP Services offers 3-year and 1-year limited warranty options depending on country.

On-site service and extended coverage is also available. HP Care Pack Services are optional extended service contracts that go beyond the standard limited warranties. To choose the right level of service for your HP product, use the HP Care Pack Services Lookup Tool at <http://www.hp.com/go/lookuptool>.

Additional HP Care Pack Services information by product is available at <http://www.hp.com/hps/carepack>.

NOTE—Certain restrictions and exclusions apply. Consult the HP Customer Support Center for details. <http://h20000.www2.hp.com/bizsupport/TechSupport/ProductRoot.jsp>

Technical Specifications

SYSTEM UNIT

Stand-Alone Power Requirements (AC Power)	Nominal Operating Voltage	19.5 V	
	Average Operating Power		Windows 7 (64-bit)
		NVIDIA Graphics	16.8 W
	Max Operating Power	< 150 W or < 200 W	
Temperature	Operating	32° to 95° F (0° to 35° C) (not writing optical) 41° to 95° F (5° to 35° C) (writing optical)	
	Non-operating	-4° to 140° F (-20° to 60° C)	
Relative Humidity	Operating	10% to 90%, non-condensing	
	Non-operating	5% to 95%, 101.6° F (38.7° C) maximum wet bulb temperature	
Shock	Operating	40 G, 2 ms, half-sine	
	Non-operating	200 G, 2 ms, half-sine	
Random Vibration	Operating	0.75 grms	
	Non-operating	1.50 grms	
Altitude (unpressurized)	Operating	-50 to 10,000 ft (-15.24 to 3,048 m)	
	Non-operating	-50 to 40,000 ft (-15.24 to 12,192 m)	
Planned Industry Standard Certifications	UL	Yes	
	CSA	Yes	
	FCC Compliance	Yes	
	ENERGY STAR®	Select models*	
	EPEAT	< 150 W or < 200 W	
	ICES	Yes	
	Australia / NZ A-Tick Compliance	Yes	
	CCC	Yes	
	Japan VCCI Compliance	Yes	
	KC	Yes	
	BSMI	Yes	
	CE Marking Compliance	Yes	

* Configurations of the HP ZBook 15 that are ENERGY STAR qualified are identified as HP ZBook 15 ENERGY STAR on HP websites and on www.energystar.gov.

** EPEAT registration varies by country. See www.epeat.net for registration status by country. EPEAT status listed above applies to U.S.

For accessibility information on HP products, please visit <http://www.hp.com/accessibility>.

DISPLAY

Technical Specifications

15.6" diagonal LED-backlit FHD UWVA IPS eDP anti-glare + Panel Self Refresh (PSR) (1920 x 1080)	Active Area (W x H)	13.54 x 7.59 in (34.4 x 19.4 cm)
	Dimensions (W x H)	15.6 in (39.6 cm)
	Weight	420 g (max)
	Surface Treatment	Anti-glare
	Contrast Ratio	600:1 (typical)
	Refresh Rate	60 Hz
	Brightness	300 nit typical
	Pixel Resolution	Format 1920 x 1080 (FHD)
		Configuration RGB Stripe
	Backlight	LED
	PPI	142
	Viewing Angle	UWVA 85/85/85/85
	15.6" diagonal LED-backlit FHD SVA eDP anti-glare (1920 x 1080)	Active Area (W x H)
Dimensions (W x H)		15.6 in (39.6 cm)
Weight		380 g (max)
Surface Treatment		Anti-glare
Contrast Ratio		400:1 (typical)
Refresh Rate		60 Hz
Brightness		300 nit typical
Pixel Resolution		Format 1920 x 1080 (FHD)
		Configuration RGB Stripe
Backlight		LED
PPI		142
Viewing Angle		SVA 45/45/25/35
15.6" diagonal LED-backlit QHD+ UWVA eDP anti-glare (3200 x 1800)		Active Area (W x H)
	Dimensions (W x H)	15.6 in (39.6 cm)
	Weight	360 g (max)
	Surface Treatment	Anti-glare
	Contrast Ratio	600:1 (typical)
	Refresh Rate	60 Hz
	Brightness	300 nit typical
	Pixel Resolution	Format 3200 x 1800 (QHD+)
		Configuration RGB Stripe
	Backlight	LED
	PPI	235
	Viewing Angle	UWVA 85/85/85/85

Technical Specifications

STORAGE AND DRIVES

Internal Storage

1 TB 7200 rpm SATA Hard Drive	Drive Weight	0.25 lbs (115g)	
	Capacity	1 TB	
	Height	0.37 in (9.5 mm)	
	Width	2.75 in (69.85 mm)	
	Interface	ATA-8, SATA 3.0,	
	Transfer Rate	Synchronous (maximum) 600 MB/s	
	Seek Time (typical reads, including settling)	Single Track	2 ms
		Average	13 ms
		Maximum	15 ms
	Cache	32 MB	
	Rotational Speed	7200 rpm	
	Logical Blocks	1,953,525,168	
	Operating Temperature	32° to 140° F (0° to 60° C) [top cover temp]	
	Features	ATA Security, S.M.A.R.T., NCQ, Ultra DMA	

750 GB 7200 rpm SATA Hard Drive	Drive Weight	0.25 lbs (115g)	
	Capacity	750 GB	
	Height	0.37 in (9.5 mm)	
	Width	2.75 in (70 mm)	
	Interface	ATA-8, SATA 3.0	
	Transfer Rate	Synchronous (maximum) 600 MB/s (Drive Capability)	
	Seek Time (typical reads, including settling)	Single Track	1.5 ms ~ 2 ms
		Average	11 ms ~ 13 ms
		Maximum	15 ms ~ 21 ms Up to 32 MB
	Cache	Up to 32 MB	
	Rotational Speed	7200 rpm	
	Logical Blocks	1,465,149,168	
	Operating Temperature	32° to 140° F (0° to 60° C) [top cover temp]	
	Features	ATA Security, NCQ, S.M.A.R.T., Ultra DMA	

Technical Specifications

500 GB 7200 rpm SATA Hard Drive	Drive Weight	0.20 lbs. (92 g) ~ 0.25 lbs (115 g)
	Capacity	500 GB
	Height	0.28 in (7 mm)/0.38 in (9.7 mm)
	Width	2.75 in (69.85 mm)
	Interface	ATA-8, SATA 3.0
	Transfer Rate	Synchronous (maximum) 600 MB/s (Drive Capability)
	Seek Time	Single Track 1.5 ms ~ 2 ms
	(typical reads, including settling)	Average 11 ms ~ 13 ms
		Maximum 18 ms ~ 22 ms
	Cache	Up To 32 MB
	Rotational Speed	7200 rpm
	Logical Blocks	976,773,168
	Operating Temperature	32° to 140° F (0° to 60° C) [top cover temp]
	Features	ATA Security, NCQ, S.M.A.R.T., Ultra DMA

500 GB 5400 rpm SATA FIPS* Hard Drive	Drive Weight	0.21 lbs. (95 g)
	Capacity	500 GB
	Height	0.28 in (7 mm)
	Width	2.75 in (69.85 mm)
	Interface	ATA-8, SATA 3.0
	Transfer Rate	Synchronous (maximum) 600 MB/s (Drive Capability)
	Seek Time	Single Track 1.5 ms
	(typical reads, including settling)	Average 11 ms
		Maximum 22 ms
	Cache	16 MB
	Rotational Speed	5400 rpm
	Logical Blocks	976,773,168
	Operating Temperature	32° to 140° F (0° to 60° C) [case temp]
	Features	ATA Security, TCG Opal SSC 2.0 and FIPS 140-2-level2

* FIPS-certified, hardware-based AES-256 encryption image.

Technical Specifications

500 GB 7200 rpm SMART SATA II Self Encrypting Drive	Drive Weight	0..21 lbs. (95 g)		
	Capacity	500 GB		
	Height	0.28 in (7 mm)		
	Width	2.75 in (69.85 mm)		
	Interface	ATA-8, SATA 2.6		
	Transfer Rate	Synchronous (maximum)	300 MB/s (Drive Capability)	
	Seek Time	Single Track	1 ms	
	(typical reads, including settling)	Average	13 ms	
		Maximum	18 ms	
	Cache	32 MB		
	Rotational Speed	7200 rpm		
	Logical Blocks	976,773,168		
	Operating Temperature	32° to 140° F (0° to 60° C) [top cover temp]		
	Features	ATA Security [†] TCG OPAL v1.00, S.M.A.R.T., NCQ, Ultra DMA		

SATA 6 Gb/s 512 GB, 2.5-inch Solid State Drive	Drive Weight	0.17 lb. (78 g)		
	Capacity	512 GB		
	Height	0.28 in (7 mm)		
	Width	2.75 in (69.85 mm)		
	Interface	ATA-8, SATA 3.0		
	Performance	Maximum Sequential Read	Maximum Sequential Write	
		460 MB/s	260 MB/s	
	Logical Blocks	1,000,215,216		
	Operating Temperature	32° to 158°F (0° to 70°C) [ambient temp]		
	Features	ATA Security [†] DIPM [†] TRIM [†] DEVSLP		

SATA 6 Gb/s 240 GB, 2.5-inch Solid State Drive	Drive Weight	0.17 lb. (78g)		
	Capacity	240 GB		
	NAND Type	MLC		
	Height	0.28 in (7 mm)		
	Width	2.75 in (69.85 mm)		
	Interface	ATA-8, SATA 3.0		
	Performance	Maximum Sequential Read	Maximum Sequential Write	
		Up to 540 MB/s	Up to 490 MB/s	
	Logical Blocks	468,862,128		
	Operating Temperature	32° to 158° F (0° to 70° C) [ambient temp]		
Features	ATA Security [†] DIPM [†] TRIM [†] DEVSLP			

Technical Specifications

SATA 6 Gb/s 180 GB, 2.5-inch Solid State Drive	Drive Weight	0.17 lb. (78g)	
	Capacity	180 GB	
	NAND Type	MLC	
	Height	0.28 in (7 mm)	
	Width	2.75 in (69.85 mm)	
	Interface	ATA-8, SATA 3.0	
	Performance	Maximum Sequential Read	Maximum Sequential Write
		Up to 540 MB/s	Up to 490 MB/s
	Logical Blocks	351,651,888	
	Operating Temperature	32° to 158° F (0° to 70° C) [ambient temp]	
Features	ATA Security [†] DIPM [†] TRIM [†] DEVSLP		

SATA 6 Gb/s 128 GB, 2.5-inch Solid State Drive	Drive Weight	0.17 lb. (78 g)	
	Capacity	128 GB	
	Height	0.28 in (7 mm)	
	Width	2.75 in (69.85 mm)	
	Interface	ATA-8, SATA 3.0	
	Performance	Maximum Sequential Read	Maximum Sequential Write
		Up to 550 MB/s	Up to 350 MB/s
	Logical Blocks	250,069,680	
	Operating Temperature	32° to 158°F (0° to 70°C) [ambient temp]	
	Features	ATA Security [†] DIPM [†] TRIM [†] DEVSLP	

Z Turbo Drive 256 GB, PCIe Solid State Drive	Drive Weight	0.02 lb. (10 g)	
	Capacity	256 GB	
	Height	0.24 in (60 mm)	
	Width	0.87 in (22 mm)	
	Interface	ATA-8, PCIe 2.0	
	Performance	Maximum Sequential Read	Maximum Sequential Write
		730 MB/s	620 MB/s
	Logical Blocks	500,118,192	
	Operating Temperature	32° to 158°F (0° to 70°C) [ambient temp]	
	Features	ATA Security [†] DIPM [†] TRIM [†] DEVSLP	

* For hard drives and solid state drives, GB = 1 billion bytes. TB = 1 trillion bytes. Actual formatted capacity is less. Up to 16 GB (for Windows 7) of system and up to 30 GB (for Windows 8) disk is reserved for system recovery software.

Optical Drives

Technical Specifications

DVD+/-RW SuperMulti DL Drive	Access Times	Random	<140ms CD (typical) < 160 ms DVD (typical)
	Max Data Transfer Rate	24X CD-ROM 8X DVD 24X CD-R 24X CD-RW 8X DVD+R 8X DVD+RW 8X DVD-R 6X DVD-RW 6X - DVD+R Dual Layer 6X - DVD-R Dual Layer 5X DVD-RAM	
	Transfer Mode	UDMA Mode 5	
	Interface	Gen 1 SATA	
	Supported Media (read)	CD-DA, CD-TEXT, CD-ROM, CD-ROM XA, MIXED MODE CD, CD-I, CD-I Bridge (Photo-CD, Video CD), Multisession CD (Photo-CD, CD-EXTRA, Portfolio, CD-R, CD-RW), CD-R, CD-RW, DVD-ROM (DVD-5, DVD-9, DVD-10, DVD-18), DVD-R, DVD-RW, DVD+R, DVD+RW, DVD-RAM	
	Supported Media (write)	CD-R, CD-RW, DVD+R, DVD+RW, DVD-R, DVD-RW, DVD-RAM, DVD+R DL, DVD-R DL	
	Max Media Capacity (read)	8.5 GB	
	Max Media Capacity (write)	8.5 GB	
	Transport	Tray Loading	
	Blu-ray ROM DVD+/-RW SuperMulti DL Drive	Access Times	Random
Max Data Transfer Rate		24X CD-ROM 8X DVD-ROM 24X CD-R 16X CD-RW 8X DVD+R 8X DVD+RW 8X DVD-R 6X DVD-RW 4X - DVD+R Dual Layer 4X - DVD-R Dual Layer 5X DVD-RAM 6X BD-ROM	
Transfer Mode		UDMA Mode 5	
Interface		Gen 1 SATA	

Technical Specifications

Supported Media (read)	CD-DA, , CD-TEXT, CD-ROM, CD-ROM XA, MIXED MODE CD, CD-I, CD-I Bridge (Photo-CD, Video CD), Multisession CD (Photo-CD, CD-EXTRA, Portfolio, CD-R, CD-RW), CD-R, CD-RW, DVD-ROM (DVD-5, DVD-9, DVD-10, DVD-18), DVD-R, DVD-RW, DVD+R, DVD+RW. DVD-RAM, BD-ROM, BD-R, BD-RE
Supported Media (write)	CD-R, CD-RW, DVD+R, DVD+R DL, DVD+RW, DVD-R, DVD-R DL, DVD-RW, DVD-RAM
Max Media Capacity (read)	50.0 GB
Max Media Capacity (write)	8.5GB
Transport	Tray Loading

Blu-ray R/RE DVD+/-RW SuperMulti DL Drive

Access Times	Random	<165 ms CD-ROM (typical) <185 ms DVD-ROM (typical) <205 ms BD-ROM (typical)
---------------------	--------	---

Max Data Transfer Rate	24X CD-ROM 8X DVD-ROM 24X CD-R 16X CD-RW 8X DVD+R 8X DVD+RW 8X DVD-R 6X DVD+R Dual Layer 6X DVD-R Dual Layer 5X DVD-RAM 6X BD-ROM 6X BD-R 2X BD-RE
-------------------------------	--

Transfer Mode UDMA Mode 5

Interface Gen 1 SATA

Supported Media (read) CD-DA, , CD-TEXT, CD-ROM, CD-ROM XA, MIXED MODE CD, CD-I, CD-I Bridge (Photo-CD, Video CD), Multisession CD (Photo-CD, CD-EXTRA, Portfolio, CD-R, CD-RW), CD-R, CD-RW, DVD-ROM (DVD-5, DVD-9, DVD-10, DVD-18), DVD-R, DVD-RW, DVD+R, DVD+RW. DVD-RAM, BD-ROM, BD-R, BD-RE

Supported Media (write) CD-R, CD-RW, DVD+R, DVD+R DL, DVD+RW, DVD-R, DVD-R DL, DVD-RW, DVD-RAM, BD-R, BD-RE

Max Media Capacity (read) 50.0 GB

Max Media Capacity (write) 50.0 GB

Transport Tray Loading

SECURITY

Technical Specifications

HP Fingerprint Sensor	Mobile Voltage Operation	3.0V-3.6V Single Supply
	Operating Temperature	14° - 167°F (-10° - 75°C)
	Current consumption image	36mA
	Low latency wait for finger	950 uA
	Capture rate	3000 lines/sec
	ESD Resistance	IEC 6100-4-2 4B (+/-15KV)
	Detection Matrix	200*1 (plus another secondary line)~508 dpi, sensor area 12*3 mm

NETWORKING/COMMUNICATIONS

Intel® I217-LM Gigabit Network Connection	Ethernet Features	<p>10 Mbit/s operation (10BASE-T~IEEE 802.3~IEEE 802.3 clauses 13-14)</p> <p>100 Mbit/s operation (100BASE-TX~IEEE 802.3u~IEEE 802.3 clauses 21-30)</p> <p>1000 Mbit/s operation (1000BASE-T~IEEE 802.3ab~IEEE 802.3. Clauses 40)</p> <p>IEEE 802.3u Auto-Negotiation (Automatic Speed Selection)</p> <p>Full Duplex Operation at all Speeds, Half Duplex operation at 10 and 100 Mbit/s</p> <p>IEEE 802.1p QoS (Quality of Service) Support</p> <p>IEEE 802.1q VLAN support</p> <p>IEEE 802.3x Flow Control (IEEE 802.3 clauses 31-32~configurable)</p> <p>IEEE 802.3az EEE(Energy Efficient Ethernet)</p> <p>IEEE 802.1as/1588 conformance</p> <p>Jumbo Frame 9K</p> <p>Auto MDI/MDIX Crossover cable detection</p>
	Power Management	<p>ACPI compliant - multiple power modes</p> <p>Energy Detect Low Power Mode(Green Ethernet)</p>
	Performance Features	<p>TCP/IP/UDP Checksum Offload (configurable)</p> <p>Protocol Offload(ARP & NS)</p> <p>Large send offload and Giant send offload</p> <p>Receiving Side Scaling</p> <p>MACSec Offload (802.3ae)</p> <p>Intel vPro</p> <p>iSCSI Boot</p>
	Manageability	<p>Wake-on-LAN from standby and hibernation (Magic Packet and Microsoft Wake-Up Frame)~Wake-on-LAN from off (Magic Packet only)</p> <p>PXE 2.1 Remote Boot</p> <p>Statistics Gathering (SNMP MIB II, Ethernet-like MIB, Ethernet MIB (802.3x, clause 30))</p> <p>Comprehensive diagnostic and configuration software suite</p> <p>Virtual Cable Doctor for Ethernet cable status</p>
	Interface	<p>PCI Express 1.1 x1 to fully support ASPM L0s/L1 and CLKREQ.</p> <p>NOTE: Intel® I217-LM Gigabit interface is not PCIe compliant. It operates at half of PCIe specification V1.1 (2.5GT/S) speed.</p>
	NIC Device Driver Name	Intel Ethernet Network Connection I217-LM

Technical Specifications

HP hs3110 HSPA+ Mobile Module*	Technology/Operating Bands	HSPA+ ⁻ 2100 (Band 1), 1900 (Band 2), 850 (Band 5), 700 (Band 17) MHz E-GPRS ⁻ 1900 (Band 2), 1800 (Band 3), 850 (Band 5), 900 (Band 8) MHz	
	Wireless Protocol Standards	WCDMA R99, 3GPP Release 5, 6 and 7 UMTS Specification E-GPRS ⁻ Class B, Multi-slot class 33, coding schemes CS1 - CS4 and MSC1 - MSC9	
	GPS	Standalone, A-GPS	
	GPS Bands	1575.42 MHz ± 1.023 MHz, GLONASS 1596-1607MHz	
	Maximum data rates	DC-HSPA+ ⁻ 42 Mbps (Download), 5.76 Mbps (Upload) HSPA+ ⁻ 21.6 Mbps (Download), 5.76 Mbps (Upload) EDGE ⁻ 236.8 kbps (Download), 236.8 kbps (Upload) GPRS ⁻ 85.6 kbps(Download), 85.6 kbps (Upload)	
	Maximum Output Power	HSPA+ ⁻ 23.5 dBm E-GPRS 1900/1800 ⁻ 26.5 dBM E-GPRS 900/850 ⁻ 27.5 dBM GPRS 1900/1800 ⁻ 29.5 dBM GPRS 900/850 ⁻ 32.5 dBm	
	Maximum Power Consumption	HSPA+ ⁻ 1,100 mA (peak) ⁻ 800 mA (average) E-GPRS ⁻ 2,800 mA (peak) ⁻ 700 mA (average)	
	Form Factor	M.2, 3042-S3 Key B	
	Weight	6g	
	Dimensions (Length x Width x Thickness)	1.65 x 1.18 x 0.09 in (42 x 30 x 2.3 mm)	
	<p>* Mobile Broadband is an optional feature. Connection requires wireless data service contract, network support, and is not available in all areas. Contact service provider to determine the coverage area and availability. Connection speeds will vary due to location, environment, network conditions, and other factors. 4G LTE not available on all products or in all countries.</p>		
	HP lt4112 LTE/HSPA+ Qualcomm® Gobi™ 4G Module *	Technology/Operating Bands	LTE ⁻ 2100 (Band 1), 1900 (Band 2), 1800 (Band 3), 850 (Band 5), 2600 (Band 7), 900 (Band 8), 800 MHz (Band 20, DD800) MHz HSPA+ ⁻ 2100 (Band 1), 1900 (Band 2), 850 (Band 5), 900 (Band 8) MHz E-GPRS ⁻ 1900 (Band 2), 1800 (Band 3), 850 (Band 5), 900 (Band 8) MHz
		Wireless Protocol Standards	3GPP Release 8 LTE Specification WCDMA R99, 3GPP Release 5, 6 and 7 UMTS Specification E-GPRS ⁻ Class B, Multi-slot class 33, coding schemes CS1 - CS4 and MSC1 - MSC9
GPS		Standalone, A-GPS	
GPS Bands		1575.42 MHz ± 1.023 MHz, GLONASS 1596-1607MHz	
Maximum data rates		LTE ⁻ 100 Mbps (Download), 50 Mbps (Upload) DC-HSPA+ ⁻ 42 Mbps (Download), 5.76 Mbps (Upload) HSPA+ ⁻ 21.6 Mbps (Download), 5.76 Mbps (Upload) EDGE ⁻ 236.8 kbps (Download), 236.8 kbps (Upload) GPRS ⁻ 85.6 kbps(Download), 85.6 kbps (Upload)	

Technical Specifications

Maximum Output Power	LTE=23 dBm HSPA+=23.5 dBm E-GPRS 1900/1800=26.5 dBm E-GPRS 900/850=27.5 dBm GPRS 1900/1800=29.5 dBm GPRS 900/850=32.5 dBm
Maximum Power Consumption	LTE=1,200 mA (peak)±900 mA (average) HSPA+=1,100 mA (peak)±800 mA (average) E-GPRS=2,800 mA (peak)±700 mA (average)
Form Factor	M.2, 3042-S3 Key B
Weight	6 g
Dimensions (Length x Width x Thickness)	1.65 x 1.18 x 0.09 in (42 x 30 x 2.3 mm)

* Mobile Broadband is an optional feature. Connection requires wireless data service contract, network support, and is not available in all areas. Contact service provider to determine the coverage area and availability. Connection speeds will vary due to location, environment, network conditions, and other factors. 4G LTE not available on all products or in all countries.

HP lt4211 LTE/EV-DO/HSPA+ Gobi 4G Module

Technology/Operating bands	LTE=1900 (Band 2), 1700/2100 (Band 4), 850 (Band 5), 700 (Band 13 upper SMH), 700 (Band 17 lower SMH), 1900 MHz (Band 25, extended PCS) MHz HSPA+=2100 (Band 1), 1900 (Band 2), 1700/2100 (Band 4), 850 (Band 5), 900 (Band 8) MHz E-GPRS=1900 (Band 2), 1800 (Band 3), 850 (Band 5), 900 (Band 8) MHz EV-DO=800 (BC0), 1900 (BC1) MHz
Wireless protocol standards	3GPP Release 8 LTE Specification WCDMA R99, 3GPP Release 5, 6 and 7 UMTS Specification E-GPRS=Class B, Multi-slot class 33, coding schemes CS1 - CS4 and MSC1 - MSC9 EVDO Release 0 and Release A
GPS	Standalone, A-GPS
GPS bands	1575.42 MHz ± 1.023 MHz, GLONASS 1596-1607MHz
Maximum data rates	LTE=100 Mbps (Download), 50 Mbps (Upload) DC-HSPA+=42 Mbps (Download), 5.76 Mbps (Upload) HSPA+=21.6 Mbps (Download), 5.76 Mbps (Upload) EDGE=236.8 kbps (Download), 236.8 kbps (Upload) GPRS=85.6 kbps(Download), 85.6 kbps (Upload) CDMA 1x=DL 153.6 kbps/UL 153.6 kbps EVDO Rev.A=DL 3.1 Mbps/UL 1.8 Mbps
Maximum output power	LTE=23 dBm HSPA+=23.5 dBm E-GPRS 1900/1800=26.5 dBm E-GPRS 900/850=27.5 dBm GPRS 1900/1800=29.5 dBm GPRS 900/850=32.5 dBm CDMA/EVDO=24dBm
Maximum power consumption	LTE=1,200 mA (peak)±900 mA (average) HSPA+=1,100 mA (peak)±800 mA (average) E-GPRS=2,800 mA (peak)±700 mA (average) EVDO=1000mA (peak)±720mA (average)

Technical Specifications

Form Factor	M.2, 3042-S3 Key B
Weight	6 g
Dimensions (Length x Width x Thickness)	1.65 x 1.18 x 0.09 in (42 x 30 x 2.3 mm)

* Mobile Broadband is an optional feature. Connection requires wireless data service contract, network support, and is not available in all areas. Contact service provider to determine the coverage area and availability. Connection speeds will vary due to location, environment, network conditions, and other factors. 4G LTE not available on all products or in all countries.

Intel® Dual Band Wireless-NB 7260 802.11 a/b/g/n (2x2) WiFi Adapter*	Wireless LAN Standards	IEEE 802.11a IEEE 802.11b IEEE 802.11g IEEE 802.11n
	Interoperability	Wi-Fi certified
	Frequency Band	802.11b/g/n <ul style="list-style-type: none"> • 2.402 - 2.482 GHz 802.11a/n <ul style="list-style-type: none"> • 4.9 - 4.95 GHz (Japan) • 5.15 - 5.25 GHz • 5.25 - 5.35 GHz • 5.47 - 5.725 GHz • 5.825 - 5.850 GHz • 2.402 - 2.482 GHz
	Data Rates	802.11b ⁻¹ , 2, 5.5, 11 Mbps 802.11g ⁻⁶ , 9, 12, 18, 24, 36, 48, 54 Mbps 802.11a ⁻⁶ , 9, 12, 18, 24, 36, 48, 54 Mbps 802.11n ^{-MCS 0 ~ MCS 15} , (20MHz, and 40MHz)
	Modulation	Direct Sequence Spread Spectrum BPSK, QPSK, CCK, 16-QAM, 64-QAM, 256-QAM
	Security¹	<ul style="list-style-type: none"> • IEEE and WiFi compliant 64 / 128 bit WEP encryption for a/b/g mode only • AES-CCMP^{-128 bit in hardware} • 802.1x authentication • WPA, WPA2^{-802.1x}. WPA-PSK, WPA2-PSK, TKIP, and AES. • WPA2 certification • IEEE 802.11i • Cisco Certified Extensions, all versions through CCX4 and CCX Lite • WAPI
	Network Architecture Models	Ad-hoc (Peer to Peer) Infrastructure (Access Point Required)
	Roaming	IEEE 802.11 compliant roaming between access points
	Output Power²	<ul style="list-style-type: none"> • 2.4G^{-+13.5dBm minimum} • 5G^{-+12dBm minimum} • Maximum output power must be able to achieve modular regulatory certification with notebooks that have antennas >20cm from the user and peak gain of +3dBi at 2.4GHz and +4dBi at 5GHz

Technical Specifications

Power Consumption	Transmit=2.0 W (max) Receive=1.6 W (max) Idle mode (PSP)=250 mW (WLAN Associated) Idle mode=100 mW (WLAN unassociated) Radio disabled=75 mW
Power Management	ACPI and PCI Express compliant power management 802.11 compliant power saving mode
Receiver Sensitivity³	802.11b=-95 dBm (1 Mbps), -93 dBm (2 Mbps), -91 dBm (5.5 Mbps), -88 dBm (11 Mbps) 802.11a/g=-90 dBm (6 Mbps), -89 dBm (9 Mbps), -87 dBm (12 Mbps), -85 dBm (18 Mbps), -82 dBm (24 Mbps), -79 dBm (36 Mbps), -76 dBm (48 Mbps), -74 dBm (54 Mbps) 802.11n=-69 dBm (72.2 Mbps), -66 dBm (300 Mbps)
Antenna type	High efficiency antenna with spatial diversity, mounted in the display enclosure Two embedded dual band 2.4/5 GHz antennas are provided to the card to support WLAN MIMO communications and Bluetooth communications
Form Factor	PCI-Express Half-MiniCard
Dimensions	0.19 x 1.06 x 1.18 in (4.75 x 26.8 x 30 mm)
Weight	3.1g
Operating Voltage	3.3v +/- 9%
Temperature	Operating 14° to 158° F (-10° to 70° C) Non-operating -40° to 176° F (-40° to 80° C)
Humidity	Operating 10% to 90% (non-condensing) Non-operating 5% to 95% (non-condensing)
Altitude	Operating 0 to 10,000 ft (3,048 m) Non-operating 0 to 50,000 ft (15,240 m)
LED Activity	LED Off - Radio OFF ² Solid LED On - Radio ON
	1. Check latest software/driver release for updates on supported security features. 2. Maximum output power may vary by country according to local regulations. 3. Receiver sensitivity is measured at a packet error rate of 8% for 802.11b (CKK modulation) and a packet error rate of 10% for 802.11a/g (OFDM modulation).
Bluetooth Specification	
Bluetooth Specification	V4.0 High Speed, V2.1+EDR, backwards compatible with V1.1, 1.2 and 2.0
Number of Available Channels	79 (1 MHz) available channels
Data Rates and Throughput	3 Mbps data rate ² throughput up to 2.17 Mbps Synchronous Connection Oriented links up to 3, 64 kbps, voice channels Asynchronous Connection Less links 2178.1 kbps/177.1 kbps asymmetric or 1306.9 kbps symmetric
Transmit Power	-6 dBm to 4 dBm (Bluetooth Class II)
Receiver Sensitivity	Better than -80 dBm at 0.1 % raw bit error rate
Power Consumption	Peak (Tx) 330 mW Peak (Rx) 230 mW Sleep <17 mW

Technical Specifications

Antenna	Internally integrated within module
Range	Up to 33 ft (10 m)
Electrical Interface	USB 2.0 compliant Microsoft Windows Plug and Play compliant
Bluetooth Software Supported	Broadcom Bluetooth for Windows Microsoft Windows Bluetooth Software
Link Topology	Point to Point, Multipoint Pico Nets up to 7 slaves
Security	Full support of Bluetooth Security Provisions
Power Management	Microsoft Windows ACPI, and USB Bus Support Self configurable to optimize power conservation in all operating modes, including Standby, Hold, Park, and Sniff
Certifications	All necessary regulatory approvals for supported countries, including— FCC (47 CFR) Part 15C, Section 15.247 & 15.249 ETS 300 328, ETS 300 826 Low Voltage Directive IEC950 UL, CSA, and CE Mark
Bluetooth Profiles Supported	Generic Access Profile (GAP) Service Discovery Application Profile (SDAP) Serial Port Profile (SPP) Dial-Up Networking Profile (DUN) Generic Object Exchange Profile (GOEP) Object Push Profile (OPP) File Transfer Profile (FTP) Synchronization Profile (SYNC) Hard Copy Cable Replacement (HCRP) Personal Area Networking Profile (PAN) Human Interface Device Profile (HID) Generic Audio/Video Distribution Profile (GAVDP) Advanced Audio/Video Distribution Profile (A2DP) FAX Profile (FAX) Basic Imaging Profile (BIP) Headset Profile (HSP) Hands Free Profile (HFP) Basic Printing Profile (BPP) VDP (Video Distribution Profile) AVRCP (Audio Video Remote Control Profile)

* Wireless access point and internet service required. Availability of public wireless access points limited. The specifications for the 802.11ac WLAN are draft specifications and are not final. If the final specifications differ from the draft specifications, it may affect the ability of the notebook to communicate with other 802.11ac WLAN devices

Intel® Dual Band Wireless-AC 7260 802.11 a/b/g/n/ac (2x2) WiFi + Bluetooth 4.0 Combo Adaptor*	Wireless LAN Standards	IEEE 802.11 a IEEE 802.11 b IEEE 802.11 g IEEE 802.11 n IEEE 802.11 ac
--	-------------------------------	--

Technical Specifications

Interoperability	Wi-Fi certified Cisco Compatible Extensions Program compliant with Microsoft Windows 7, Windows Vista and XP (details at http://www.hp.com/go/notebooks/WLAN)
Frequency Band	802.11b/g/n 2.402 - 2.482 GHz 802.11a/n 4.9 - 4.95 GHz (Japan) 5.15 - 5.25 GHz 5.25 - 5.35 GHz 5.47 - 5.725 GHz 5.825 - 5.850 GHz
Antenna Structure	2 transmit/2 receive (2x2)
Data Rates	802.11a=6, 9, 12, 18, 24, 36, 48, 54 Mbps 802.11b=1, 2, 5.5, 11 Mbps 802.11g=6, 9, 12, 18, 24, 36, 48, 54 Mbps 802.11n=card will support rates for NSS=1 and NSS=2 for RX and TX for 20 and 40 MHz channels. Short and long guard interval shall be supported.
Modulation	Direct Sequence Spread Spectrum CCK, BPSK, QPSK, 16-QAM, 64-QAM
Security¹	<ul style="list-style-type: none"> • IEEE and WiFi compliant 64 / 128 bit WEP encryption for a/b/g mode only • AES-CCMP=128 bit in hardware • 802.1x authentication • WPA, WPA2=802.1x. WPA-PSK, WPA2-PSK, TKIP, and AES. • WPA2 certification • IEEE 802.11i • Cisco Certified Extensions, all versions through CCX4 and CCX Lite • WAPI
Sub-channels	Multinational support with frequency bands and channels compliant to local regulations.
Network Architecture Models	Ad-hoc (Peer to Peer) Infrastructure (Access Point Required)
Roaming	IEEE 802.11 compliant roaming between band Access Points
Output Power²	<ul style="list-style-type: none"> • 2.4G=+13.5dBm minimum • 5G=+12dBm minimum
Power Consumption	Transmit=2.0 Watts Receive=1.6 Watts Idle mode ³ =250 mW (WLAN Associated) Idle mode=100 mW (WLAN unassociated) Radio off=75 mW
Power Management	ACPI and PCI Express compliant power management 802.11 compliant power saving mode
Receiver Sensitivity⁴	802.11g=90 dBm (6 Mbps), -89 dBm (9 Mbps), -87 dBm (12 Mbps), -85 dBm (18 Mbps), -82 dBm (24 Mbps), -79 dBm (36 Mbps), -76 dBm (48 Mbps), -74 dBm (54 Mbps) 802.11b=95 dBm (1 Mbps), -93 dBm (2 Mbps), -91 dBm (5.5 Mbps), -88 dBm (11 Mbps) 802.11g=90 dBm (6 Mbps), -89 dBm (9 Mbps), -87 dBm (12 Mbps), -85 dBm (18 Mbps), -82 dBm (24 Mbps), -79 dBm (36 Mbps), -76 dBm (48 Mbps), -74 dBm (54 Mbps)

Technical Specifications

	802.11n—69 dBm (150 Mbps), -66 dBm (300 Mbps)
Antenna Connections	2 U.FL type connectors (output impedance of 50 ± 2 ohms)
Form Factor	PCI-Express Half-MiniCard
Dimensions	0.12 x 1.06 x 1.18 in (3.1 x 26.8 x 30.0 mm)
Weight	3.1g
Operating Voltage	3.3v +/- 9%
Temperature	Operating 14° to 158° F (-10° to 70° C) Non-operating -40° to 176° F (-40° to 80° C)
Humidity	Operating 10% to 90% (non-condensing) Non-operating 5% to 95% (non-condensing)
Altitude	Operating 0 to 10,000 ft (3,048 m) Non-operating 0 to 50,000 ft (15,240 m)
LED Activity	LED Off - Radio OFF—Solid LED On - Radio ON

1. Check latest software/driver release for updates on supported security features.
2. Maximum output power may vary by country according to local regulations.
3. In Power Save Polling mode and on battery power.
4. Receiver sensitivity is measured at a packet error rate of 8% for 802.11b (CCK modulation) and a packet error rate of 10% for 802.11a/g (OFDM modulation).
5. WLAN supplier's client utility is required for Cisco Compatible Extensions support with Microsoft Windows XP. WLAN may also be compatible with certain third-party software supplicants. WLAN supplier IHV extensions required for Cisco Compatible Extensions support for Microsoft Windows Vista.

HP Integrated Module with Bluetooth 4.0+EDR Wireless Technology

Bluetooth Specification	4.0+EDR Compliant
Dimensions	1.18 x 0.26 x 0.13 in (30 x 6.5 x 3.25 mm)
Frequency Band	2402 to 2480 MHz
Number of Available Channels	79 (1 MHz) available channels
Data Rates and Throughput	3 Mbps data rate—throughput up to 2.17 Mbps Synchronous Connection Oriented links up to 3, 64 kbps, voice channels Asynchronous Connection Less links 2178.1 kbps/177.1 kbps asymmetric or 1306.9 kbps symmetric
Transmit Power	-1.5 dBm to 4 dBm (Bluetooth Class II)
Receiver Sensitivity	Better than -20 dBm at 0.1 % raw bit error rate
Power Consumption	Peak (Tx) 264 mW Peak (Rx) 231 mW Sleep <1 mW
Antenna	Internally integrated within module
Range	Up to 33 ft (10 m)
Electrical Interface	USB 2.0 compliant Microsoft Windows Plug and Play compliant
Bluetooth Software Supported	Broadcom Bluetooth for Windows Microsoft Windows Bluetooth Software
Link Topology	Point to Point, Multipoint Pico Nets up to 7 slaves
Security	Full support of Bluetooth Security Provisions

Technical Specifications

Power Management	Microsoft Windows ACPI, and USB Bus Support Self configurable to optimize power conservation in all operating modes, including Standby, Hold, Park, and Sniff
Certifications	All necessary regulatory approvals for supported countries, including— FCC (47 CFR) Part 15C, Section 15.247 & 15.249 ETS 300 328, ETS 300 826 Low Voltage Directive IEC950 UL, CSA, and CE Mark
Bluetooth Profiles Supported	Serial Port Profile (SPP) ¹ Service Discovery Application Profile (SDAP) Dial-Up Networking (DUN) ^{1,2} Generic Object Exchange Profile (GOEP) ^{1,2} Object Push Profile (OPP) ^{1,2} File Transfer Profile (FTP) Synchronization Profile (SYNC) Hard Copy Cable Replacement (HCRP) ^{1,2} Personal Area Networking Profile (PAN) ^{1,2} Human Interface Device Profile (HID) ^{1,2} FAX Profile (FAX) Basic Imaging Profile (BIP) ² Headset Profile (HSP) Hands Free Profile (HFP) Advanced Audio Distribution Profile (A2DP)

1. indicates the profile is supported by Microsoft Windows XP SP2

2. indicates the profile is part of Windows Vista

* Wireless access point and internet service required. Availability of public wireless access points limited.

AUDIO/MULTIMEDIA

AUDIO/MULTIMEDIA - DTS SOUND+

Hardware	Implementation	IDT 92HD91
	Function Key	Volume up, volume down, and mute
	Volume Controls	
	Full Duplex	Yes
	Microphone In	Stereo
	Headphone/Line Out	Stereo
	Integrated Microphone	Yes, dual digital microphone array when equipped with optional webcam

Technical Specifications

Audio Output Quality	Frequency Response	20 Hz - 20 kHz
	Signal to Noise Ratio	>85 dB
	Total Harmonic Distortion	0.01%
	Noise Floor	-110 dB
	Play/Record Sampling Rate(s)	8 kHz - 48kHz
	DAC	16, 20 or 24-bit
	ADC	16 or 20-bit

Internal Stereo Speaker	Power Rating	2 Watts
	Impedance	4 ohms

POWER

HP 200W Slim Smart AC Adapter	Dimensions	6.77 x 3.80 x 1.0 in (172 x 96 x 25.4 mm)		
	Weight	1.65 lb (748 g)		
	Input	Input	100 to 240 VAC	
		Input Efficiency	87% min at 115 VAC	
		Input frequency range	47 to 63 Hz	
	Output	Input AC current	2.9 A at 90 VAC, 1.45 A at 180 VAC	
		Output power	200W	
		DC output	19.5V	
		Hold-up time	5 msec at 115 VAC input	
		Output current limit	<16A, Over voltage protection- 29V max automatic shutdown	
	Connector	3 pin/grounded, mates with interchangeable cords		
	Environmental Design	Operating temperature	32° to 104° F (0° to 40° C)	
		Non-operating (storage) temperature	-4° to 149° F (-20° to 65° C)	
		Altitude	0 to 10,000 ft (0 to 3,048 m)	
		Humidity	20% to 80%	
Storage Humidity		10% to 90%		
EMI and Safety Certifications	CE Mark- full compliance with LVD and EMC directives [†] Worldwide safety standards- IEC950, EN60950, UL1950, Class 1, SELV [†] Agency approvals- C-UL- US, NORDICS, DENAN, EN55022 Class B, FCC Class B, CISPR22 Class B, CCIB, NOM-1 NYCE [†] MTBF- over 200,000 hours at 25°C ambient condition.			

Technical Specifications

HP 150W Slim Smart AC adapter	Dimensions	6.59 x 3.23 x 1.0 in (167.5 x 82 x 25.4 mm)	
	Weight	1.25 lb (565 g)	
	Input	Input	100 to 240 VAC
		Input Efficiency	87% min at 115 VAC
		Input frequency range	47 to 63 Hz
		Input AC current	<2.7 A at 90 VAC
	Output	Output power	150W
		DC output	19.50V +5.0%/-5.0%
		Hold-up time	5 msec at 115 VAC input
		Output current limit	<15A, Over voltage protection- 29V max automatic shutdown
		Connector	3 pin/grounded, mates with interchangeable cords
	Environmental Design	Operating temperature	41° to 95° F (5° to 35° C)
		Non-operating (storage) temperature	-4° to 185° F (-20° to 85° C)
		Altitude	0 to 10,000 ft (0 to 3,048 m)
Humidity		10% to 95%	
Storage Humidity		10% to 95%	
EMI and Safety Certifications	Worldwide safety and EMC approvals including CE, UL, CSA or cUL, GS, Australian Electric Permit, C-tick, NOM, CCC, KC, GOST, SABS, S mark, BSMI, ISC, PSE, PSB and SIL.		
HP 8-cell Lithium-Ion Battery (83 WHr)	Dimensions (H x W x L)	0.8 x 2.1 x 10.6 in (2 x 5.3 x 27cm)	
	Weight (max)	0.99lb (0.442 kg)	
	Cells/Type	Lithium-Ion	
	Energy	Voltage	14.8V
		Amp-hour capacity	5.6Ah
		Watt-hour capacity	83Wh
	Temperature	Operating (Charging)	32° to 113° F (0° to 45° C)
		Operating (Discharging)	14° to 122° F (-10° to 50° C)
		Non-operating	-4° to 122° F (-20° to 50° C)
	Battery Re-Charge Time	System in OFF or Standby Mode	2.5 hours
		System ON	3 to 5 hours
Fuel Gauge LED	No		
Warranty	1 year		
Compatible with optional Travel Battery	Yes		

Technical Specifications

HP Long Life 8-cell Lithium-Ion Battery (75 WHr)	Dimensions (H x W x L)	0.8 x 2.1 x 10.6 in (2 x 5.3 x 27cm)		
	Weight (max)	0.99lb (0.442 kg)		
	Cells/Type	8-cell [†] Lithium-Ion		
	Energy	Voltage	14.4V	
		Amp-hour capacity	5.1Ah	
		Watt-hour capacity	75Wh	
	Temperature	Operating (Charging)	32° to 113° F (0° to 45° C)	
		Operating (Discharging)	14° to 140° F (-10° to 60° C)	
		Non-operating	-4° to 140° F (-20° to 60° C)	
	Battery Re-Charge Time	System in OFF or Standby Mode	2.5 hours	
		System ON	3 to 5 hours	
	Fuel Gauge LED	No		
	Warranty*	3 year		
Compatible with optional Travel Battery	Yes			

* 3-year platform warranty is required for a 3-year Long Life Battery warranty.

Optional HP BB09 Ultra Extended Life Notebook Battery (secondary battery)	Dimensions (H x W x L)	1.2 x 5.9 x 11.4 in (3x15x29cm)		
	Weight (max)	1.5lb, (.682kg)		
	Cells/Type	Lithium-Ion		
	Energy	Voltage	11.25V	
		Amp-hour capacity	8.85Ah	
		Watt-hour capacity	100Wh	
	Temperature	Operating (Charging)	32° to 113° F (0° to 45° C)	
		Operating (Discharging)	14° to 122° F (-10° to 50° C)	
		Non-operating	-4° to 122° F (-20° to 50° C)	
	Battery Re-Charge Time	System in OFF or Standby Mode	3.5 to 5 hours	
		System ON	4 to 7 hours	
	Fuel Gauge LED	Yes		
	Warranty	1 year		
Compatible with optional Travel Battery	No			

Technical Specifications

Optional HP ST09 Extended Life Notebook Battery (Travel Battery) (secondary battery)	Dimensions (H x W x L)	1.2 x 6.1 x 12 in (3x15.5x30.5cm)
	Weight (max)	1.2lb, (.550kg)
	Cells/Type	Lithium-Ion Polymer
	Energy	Voltage 11.1V
		Amp-hour capacity 6.6Ah
		Watt-hour capacity 73Wh
	Temperature	Operating (Charging) 32° to 113° F (0° to 45° C)
		Operating (Discharging) 14° to 122° F (-10° to 50° C)
		Non-operating -4° to 122° F (-20° to 50° C)
	Battery Re-Charge Time	System in OFF or Standby Mode 3.5 to 5 hours
		System ON 4 to 7 hours
	Fuel Gauge LED	Yes
	Warranty	1 year
	Compatible with optional Travel Battery	Yes

ENVIRONMENTAL

US ENERGY STAR®
IT ECO declaration
EPEAT®

COUNTRY OF ORIGIN

China

Options and Accessories (sold separately and availability may vary by country)

Type	Description	Part #
Memory	HP 4 GB DDR3L-1600 1.35V SODIMM	H6Y75AA#xxx
	HP 8 GB DDR3L-1600 1.35V SODIMM	H6Y77AA#xxx
Cases	HP Business Top Load Case (fits up to 15.6")	H5M92AA
	HP Business Backpack (fits up to 17.3")	H5M90AA
	HP Essential Top Load Case (up to 15.6")	H2W17AA#xxx
	HP Professional Leather Case (up to 17.3")	H4J94AA
	HP Business 4 Wheel Roller Case (fits up to 17.3")	H5M93AA
Docking	HP Adjustable Dual Monitor Stand	AW664AA#xxx
	HP Adjustable Display Stand	AW663AA#xxx
	HP Dual Hinge II Notebook Stand	E8F99AA
	HP Display and Notebook II Stand	E8G00AA
	HP 230W Docking Station	A7E34AA#xxx
	HP 230W Advanced Docking Station	A7E38AA#xxx
	HP 3005pr USB 3.0 Port Replicator	H1L08AA
	HP 3001pr USB 3 Port Replicator	F3S42AA
	HP Universal Port Replicator	E6D70AA#xxx
Input/Output - Mice	Comfort Grip Mouse	H2L63AA
	HP Stylish USB KB/Mouse	H4B80AA#xxx
	HP Slim Bluetooth Keyboard	H4Q44AA#xxx
	HP 3-Button Laser Mouse	H4B81AA#xxx
	HP USB Essential Keyboard and Mouse	H6L29AA#xxx
	HP Ultra Mobile Wireless Mouse	H6F25AA#xxx
	HP Wireless Keyboard and Mouse	G1K29AA#xxx
	HP X4000 Bluetooth Mouse	H3T50AA#xxx
	USB Graphics Adapter	NL571AT
	HP Slim Bluetooth Mouse	F3J92AA#xxx
HP USB Smart Card Reader	F6V67AA	
Power Adapters	HP 90W Slim AC Adapter	H6Y83AA#xxx
	HP 150W Smart AC Adapter (slim)	AL192AA#xxx
	HP 90W Slim Combo Adapter w/USB Adapter	H6Y84AA#xxx
	90W Smart AC/Auto/Air Combo Adapter	AJ652AA#xxx
	90W Smart Auto/Truck Adapter	ED493AA
	90W Slim Adapter	BT796AA#XXX
	HP Smart 230W AC Adapter	AT895AA#xxx
	HP 230W Slim Adapter	H1D36AA#xxx
	HP 90W Smart AC Adapter	H6Y90AA#xxx
	HP 65W Slim AC Adapter	H6Y82AA#xxx

Options and Accessories (sold separately and availability may vary by country)

Adapters	HP Wireless display adapter	J1V25AA#xxx
	USB dual output graphics adapter	C5U89AA
	DisplayPort to DVI Adapter	F7W96AA
	DisplayPort to VGA Adapter	F7W97AA
	DisplayPort to HDMI Adapter	F3W43AA
	Adapter, USB Graphics - dual output (Monitor Accy)	C5U89AA/AT
Storage - External Storage	HP 2013 MWS Upgrade Bay DVD	G1Y57AA
	HP 2013 MWS Upgrade Bay 750GB HDD	G1Y56AA
	HP External USB Optical Drive	F2B56AA
	HP 500GB 7200rpm HDD	F3B97AA
	HP 750GB 7200rpm HDD	H2P67AA
	HP 128GB Solid State Drive	F4P50AA
	HP 180GB Solid State Drive	H4T75AA
	HP 512GB Solid State Drive	J2V75AA
HP MWS HDD/SDD Bracket Only	J2D73AA	
Batteries	HP ST09 Extended Life Notebook Battery	QK639AA
	HP BB09 Ultra Extended Life Notebook Battery	QK640AA
	HP AR08XL Notebook Battery	E7U26AA
Health and Education	HP 20-Notebook Managed Charging Cart	QL489AA#xxx
	HP 20-Notebook Charging Cart	QL488AA#xxx
	HP 30-Notebook Managed Charging Cart	QL490AA#xxx
	HP 30-Notebook Charging Cart	H4F31AA#xxx
Security	HP Docking Station Cable Lock	AU656AA#xxx
	HP UltraSlim Keyed Cable Lock	H4D73AA
Wireless	HP hs3110 HSPA+ Mobile Module	J8F05AA
	HP lt4211 LTE/EV-DO/HSPA+ WWAN	J8F06AA
	HP lt4112 LTE/HSPA+ W8.1 WWAN	J8F07AA

Summary of Changes

Date	Version History	Action	Description of Change
Sept 15, 2014	From v1 to v2	Removed	DreamColor references, Win 8.1 Remote Graphics note
October 31, 2014	From v2 to v3	Changed	Change URL from ISV and change the value for AMD FirePro under graphics, partnership link
		Removed	Remove 65 watt from Options and box 50 GB and its note from HP value add

Copyright © 2014 Hewlett-Packard Development Company, L.P.

All rights reserved. All trademarks are the property of their respective owners. Intel, Core, and Celeron are registered trademarks or trademarks of Intel Corporation in the U.S. and/or other countries. Bluetooth is a registered trademark of Bluetooth SIG, Inc., in the U.S. and other countries. Adobe is a trademark of Adobe Systems Incorporated. All other product names mentioned herein may be trademarks of their respective companies.

The information contained herein is subject to change without notice and is provided as is without warranty of any kind. The warranties for HP products are set forth in the express limited warranty statements accompanying such products. Nothing herein should be construed as constituting an additional warranty. HP shall not be liable for technical or editorial errors or omissions contained herein.